

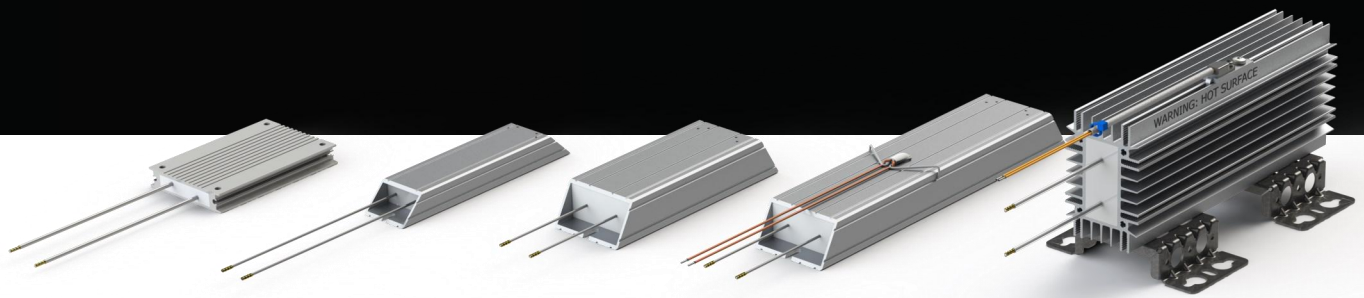

DANOTHERM™



CCH / CAH / CBH / CBR-V

- Standard Power resistors

- General-purpose applications; High pulse load and High average load
- Standard program, fixed ohmic values E6
- Connection type–flying leads
- Compact Construction; small dimensions
- Fully insulated; no external live parts
- High IP Classes
- Low thermal drift, 100ppm/K
- Low noise
- UL approved
- External thermal switch optional

Danotherm Electric A/S designs and manufactures high power resistors for a variety of applications. These products are used in electronic variable speed drives as braking resistors for the control of speed or position in elevators, escalators, cranes and conveyor belts, where re-generated energy needs to be dissipated and also in renewable energy systems, such as wind turbines, solar inverters, wave and tidal generators and kite power systems.

These resistors are also used in electronic circuits for capacitor charging and discharging, voltage balancing, snubbers and filters. The products in this overview are standard parts with fixed ohmic values and flying lead connections. An optional thermal switch is available, to be fitted externally, to monitor the surface temperature of the case.

Provided below are tables with overload durations from 1 to 40 seconds within a cycle period of 120 seconds. When in doubt, please contact your local Danotherm distributor or Danotherm directly for help with the appropriate selection.

Construction and properties

- Compact dimensions
- Nominal power range from 75W–525W
- Overload $10\text{--}16 \times P_{\text{nom}}$, (5 seconds pulse, 120s cycle), depending on ohmic value
- Aluminium case housing for high IP rating
- IP54
- Internal ceramic supported wirewound spirals for lower ohmic values
- Internal mica supported wirewound elements for higher ohmic values
- Nickel-Chrome 8020 alloy for low thermal drift
- Mica insulated for high dielectric strength
- SiO_2 filled for high thermal capacity/high power overload capability
- Low surface temperature
- Low noise level
- High vibration withstand capability
- Thermal relief expansion mounting feet
- Optional thermal switch for thermal protection
- Cable size AWG 16 (1.3mm^2), 300mm long
- UL approved



CCH 110

Product Selection table

Type	P _{nom} [W]	Max. housing temp @ 40°C	6R8	10R	15R	22R	33R	47R	68R	100R	150R	220R	330R	470r
CCH 110 C	100	260						X	X	X	X	X	X	X
CAH 165 C	75	270		X	X	X	X	X	X	X	X	X		
CBH 165 C	110	270		X	X	X	X	X	X	X	X	X		
CBH 265 C	200	280		X	X	X	X	X	X	X	X	X		
CBR 225 C	400	280	X	X	X		X		X					
CBR 295 C	525	290	X	X		X		X		X				

Quick Selection table for impulse load applications

Duty time Brake Power	duty time square impulse load / 120s cycle time				
	1 sec [kW]	5 sec [kW]	10 sec [W]	20 sec [W]	40 sec [W]
CCH 110	1.55 - 1.9	0.87 - 0.98	660	460	290
CAH 165	1.5 - 4.3	0.775 - 1.050	630	440	220
CBH 165	2.3 - 6.7	1.0 - 1.6	840	570	330
CBH 265	7.5 - 16.2	2.8 - 4.6	2,200	1,250	620
CBR-V 225	12 - 17.8	3.2 - 5.2	2,800	1,750	1,100
CBR-V 295	22.5 - 30.3	5.6 - 8.3	4,200	2,500	1,550

Thermal switch kits

Part number	Part name	Housing type	Temperature [°C]	Mounting concept
P36425	CAH thermostat kit 180 deg.	CAH	180	Clip
P36426	CBH thermostat kit 180 deg.	CBH	180	Clip
P363911	CBR thermostat kit 180 deg.	CBR	180	Screw

Optionally, an external thermal switch can be mounted on the resistor body. When fixing this thermal switch in the middle (hot spot), the surface temperature will be limited to the thermal switch temperature (180°C). When fixing the thermal switch towards the end of the resistor body, the maximum surface temperature (in the same hot spot) will be higher before tripping. Surface temperature reaching 250°C is technically not a problem for the resistor. All materials used are selected to comply with such a high value. The temperature switch can detect the surface temperature of the resistor. It will not protect the internal active resistor-wire from excessive impulse load.

To protect the internal resistor-wire when applying an impulse load, the thermal model which is available for each resistor can be used to calculate the internal temperature. Consult your Danotherm distributor for assistance.

General specifications		
Temperature Coefficient:		100 ppm/K
Dielectric strength		3500 VAC @ 1 minute
Insulation Resistance:		> 20MΩ / case housing
Environmental:		-40 °C / +70 °C
Surface temperature	At 40°C ambient	260-290°C @ nominal power (depending on housing type) No heatsink is required. When heatsink or forced air is used nominal power can be increased
De-rating		Linear: 40°C = Pn to 70°C = 0.85 * Pn
De-rating vertical mounting		no de-rating
De-rating horizontal mounting	Only CBR	0.8 * Pn
De-rating at high altitudes	1000 m	no de-rating
	1500 m	0.94 * Pn
	3000 m	0.82 * Pn
Mounting instructions		It is recommended to keep a distance of 200mm to the nearest object to prevent heating of neighboring components.
		If two or more brake resistors are mounted next to each other the distance between should be 400mm. Shorter distance requires de-rating.
Cooling		The nominal power of the resistors refers to cooling conditions with Free Natural Air Cooling at 40°C ambient.
Vibration		Acc. To EN 60068-2-6 frequency range 1 - 100Hz Acceleration / Amplitude
	1 - 13 Hz	± 1mm
	13 - 100 Hz	@ ± 0.7G
Corrosive resistance		Acc. EN 60721-2-1: C2 medium
Resistance tolerance		± 10%
Working voltage		UL: 600VAC / 850VDC IEC: 690VAC / 975VDC
Time constant for heating up resistor		1000 s
Thermal switch (optional)	Thermal switch	180°C / 2.5A / 250 VAC / NC
Minimum voltage		2V
Minimum current		10mA
Rated current / voltage		2.5A @ 250 VAC cos φ=1
Dielectric voltage		2000VAC (3500VAC between TS and R)

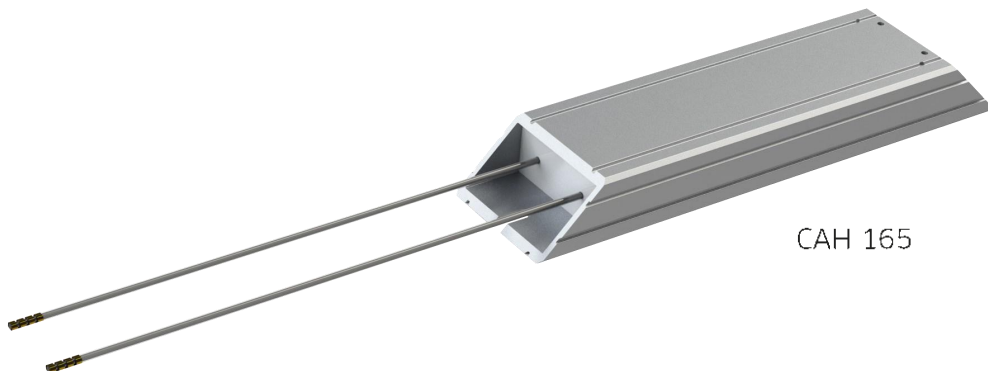

CAH 165

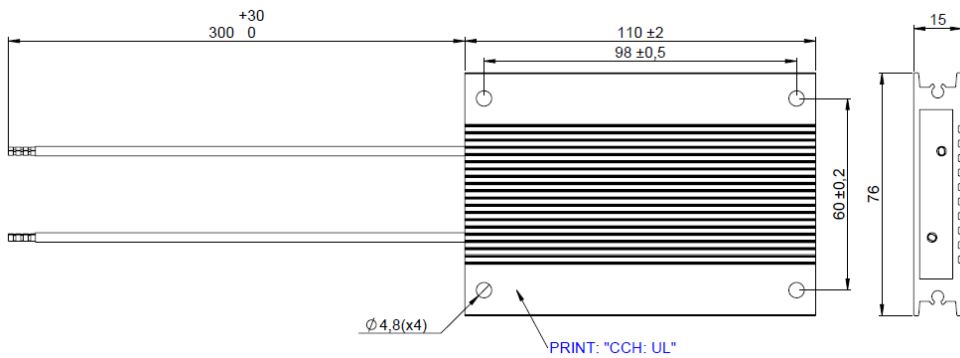

Type	Length mm	Weight g
CCH	110	250

Part number	Part name	Housing length [mm]	Ohm value [Ω]	Power rating [W]	Pulse load [W] T.amb = 40°C, cycle time 120s				
					Duty 1s	Duty 5s	Duty 10s	Duty 20s	Duty 40s
Z5113247777	CCH 110 C 777 47R KT	110	47	100	1900	975	700	475	290
Z5113268777	CCH 110 C 777 68R KT	110	68	100	1700	910	660	460	290
Z5113310777	CCH 110 C 777 100R KT	110	100	100	1650	895	660	460	295
Z5113315777	CCH 110 C 777 150R KT	110	150	100	1700	920	665	465	290
Z5113322777	CCH 110 C 777 220R KT	110	220	100	1600	875	645	455	290
Z5113333777	CCH 110 C 777 330R KT	110	330	100	1550	880	645	455	290
Z5113347777	CCH 110 C 777 470R KT	110	470	100	1600	910	660	460	290

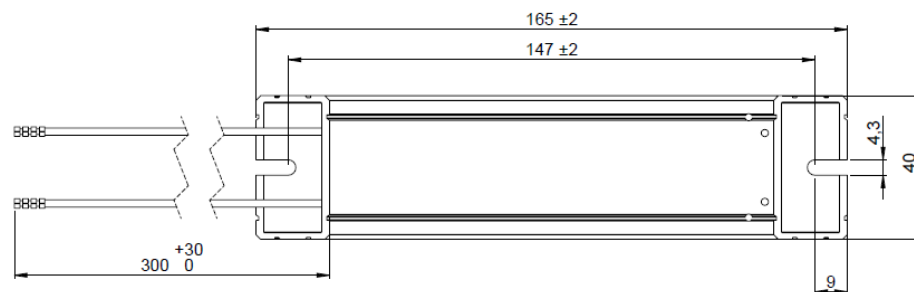
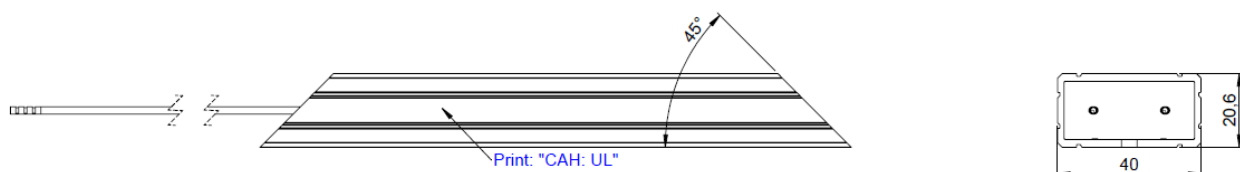

Type	Length mm	Weight g
CAH	165	220

Part number	Part name	Housing length [mm]	Ohm value [Ω]	Power rating [W]	Pulse load [W] T.amb = 40°C, cycle time 120s				
					Duty 1s	Duty 5s	Duty 10s	Duty 20s	Duty 40s
Z1163210777	CAH 165 C 777 10R KT	165	10	75	4300	1050	660	435	225
Z1163215777	CAH 165 C 777 15R KT	165	15	75	3600	965	625	420	225
Z1163222777	CAH 165 C 777 22R KT	165	22	75	3800	980	630	425	225
Z1163233777	CAH 165 C 777 33R KT	165	33	75	2900	935	675	440	220
Z1163247777	CAH 165 C 777 47R KT	165	47	75	2200	845	635	445	220
Z1163268777	CAH 165 C 777 68R KT	165	68	75	1850	805	620	445	225
Z1163310777	CAH 165 C 777 100R KT	165	100	75	1700	785	615	440	220
Z1163315777	CAH 165 C 777 150R KT	165	150	75	1650	780	615	445	220
Z1163322777	CAH 165 C 777 220R KT	165	220	75	1500	775	610	440	220

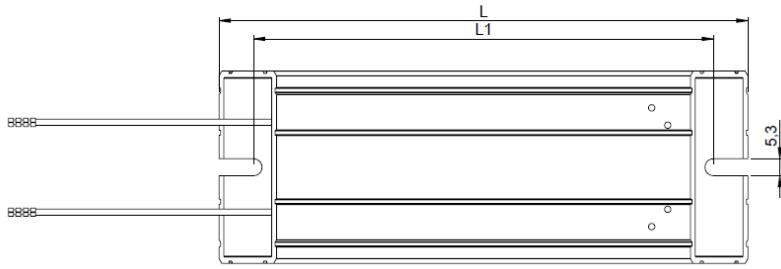
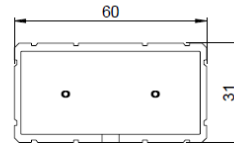
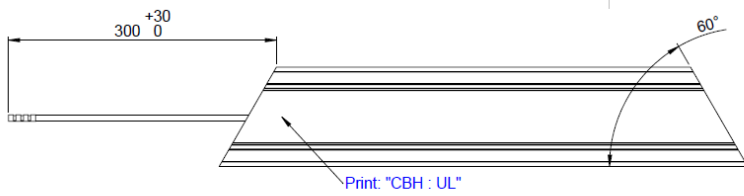

Type	L ± 2 mm	L1 ± 2 mm	Weight g
CBH	165	143.5	390
CBH	265	243.5	880

Part number	Part name	Housing length [mm]	Ohm value [Ω]	Power rating [W]	Pulse load [W] T.amb = 40°C, cycle time 120s				
					Duty 1s	Duty 5s	Duty 10s	Duty 20s	Duty 40s
Z3163210777	CBH 165 C 777 10R KT	165	10	110	6700	1600	940	590	330
Z3163215777	CBH 165 C 777 15R KT	165	15	110	6100	1500	895	580	335
Z3163222777	CBH 165 C 777 22R KT	165	22	110	5200	1300	835	555	335
Z3163233777	CBH 165 C 777 33R KT	165	33	110	4000	1150	760	535	335
Z3163247777	CBH 165 C 777 47R KT	165	47	110	3400	1150	840	590	330
Z3163268777	CBH 165 C 777 68R KT	165	68	110	3100	1100	825	585	330
Z3163310777	CBH 165 C 777 100R KT	165	100	110	2600	1050	805	575	330
Z3163315777	CBH 165 C 777 150R KT	165	150	110	2400	1050	800	575	330
Z3163322777	CBH 165 C 777 220R KT	165	220	110	2300	1050	790	570	330
ZH3263210777	CBH 265 CH 777 10R KT	265	10	200	15900	4600	2400	1200	610
ZH3263215777	CBH 265 CH 777 15R KT	265	15	200	15800	4600	2500	1250	615
Z3263222777	CBH 265 C 777 22R KT	265	22	200	14600	3500	2100	1200	630
Z3263233777	CBH 265 C 777 33R KT	265	33	200	16200	3800	2200	1250	625
Z3263247777	CBH 265 C 777 47R KT	265	47	200	13900	3400	2100	1250	620
Z3263268777	CBH 265 C 777 68R KT	265	68	200	11200	3000	1900	1250	620
Z3263310777	CBH 265 C 777 100R KT	265	100	200	10200	3100	2100	1250	615
Z3263315777	CBH 265 C 777 150R KT	265	150	200	8400	2900	2000	1250	615
Z3263322777	CBH 265 C 777 220R KT	265	220	200	7500	2800	2000	1200	610

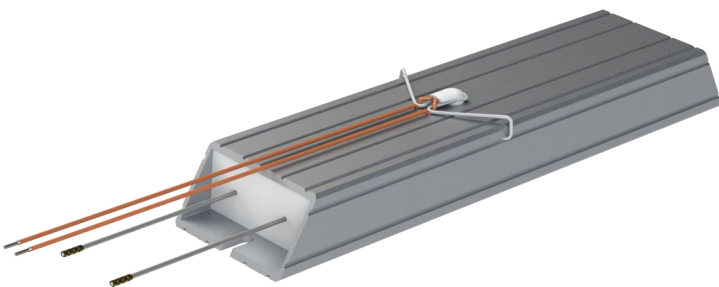

CBH 265 + Thermal switch



CBH 165

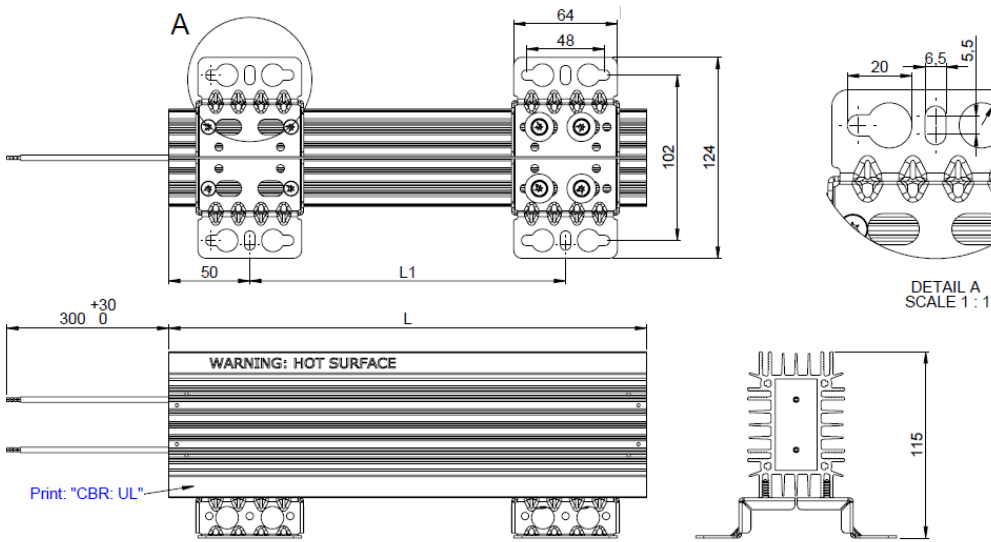

Type	L ± 2 mm	L1 ± 2 mm	Weight g
CBR-V	225	125	1800
CBR-V	295	195	2300

Part number	Part name	Housing length [mm]	Ohm value [Ω]	Power rating [W]	Pulse load [W] T.amb = 40°C, cycle time 120s				
					Duty 1s	Duty 5s	Duty 10s	Duty 20s	Duty 40s
ZH9223168777	CBR-V 225 CH 777 6R8 KT	225	6.8	400	17200	5200	3100	1900	1150
ZH9223210777	CBR-V 225 CH 777 10R KT	225	10	400	17300	5200	3100	1900	1150
ZH9223215777	CBR-V 225 CH 777 15R KT	225	15	400	17200	5200	3200	1900	1150
Z9223233777	CBR-V 225 C 777 33R KT	225	33	400	17800	4200	2600	1650	1050
Z9223268777	CBR-V 225 C 777 68R KT	225	68	400	12000	3200	2200	1500	1000
ZH9293168777	CBR-V 295 CH 777 6R8 KT	295	6.8	525	30300	8300	4800	2800	1600
ZH9293210777	CBR-V 295 CH 777 10R KT	295	10	525	25000	7400	4500	2700	1600
ZH9293222777	CBR-V 295 CH 777 22R KT	295	22	525	25000	7600	4600	2700	1600
Z9293247777	CBR-V 295 C 777 47R KT	295	47	525	25000	6000	3600	2300	1450
Z9293310777	CBR-V 295 C 777 100R KT	295	100	525	22500	5600	3400	2200	1450



CBR-V 225 + Thermal switch

Overview of the ALPHA resistor family

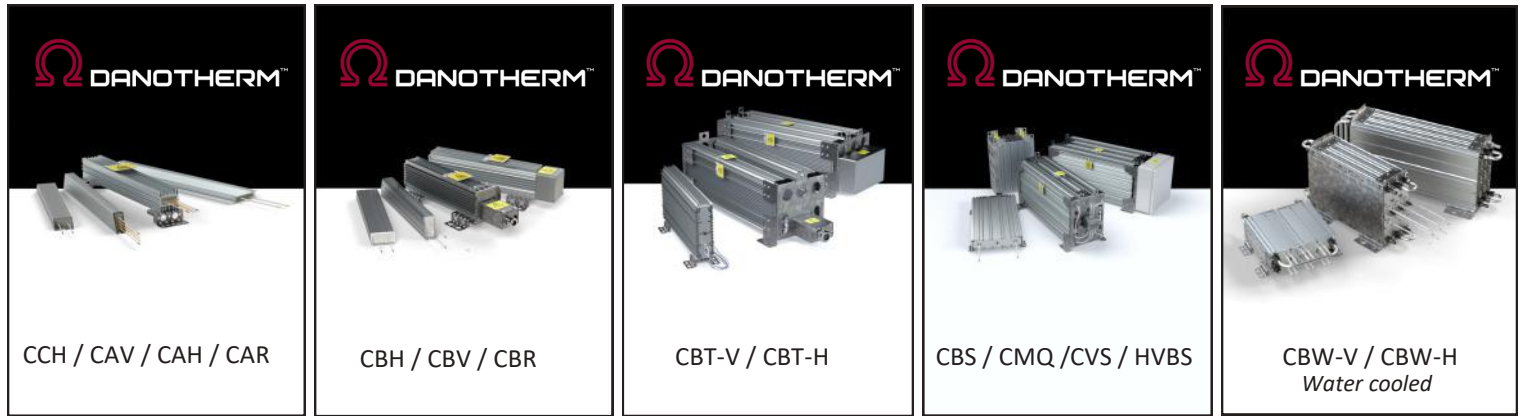

Power: 60-410W	Power: 85W-1.7kW	Power: 410W-12kW	Power: 445W-15kW	Power: 860W-25kW
	9-150kJ @5s	25-550kJ @5s	80kJ-2.5MJ @5s	6.4kJ-1.1MJ @5s
- Applications				
Charge / Discharge	High Pulse load	High Pulse load	High Pulse load	Short recovery time
Brake	Brake	Brake	Brake	Brake
Filter	Filter	Filter	Medium voltage	Filter
	Charge / Discharge	Charge / Discharge	Charge / Discharge	High Pulse load

Other resistor types from Danotherm (IP00-IP66)



Multi purpose	Outdoor & Marine	Filter	Medium & High voltage	Filter & load
Power: 100W-5kW	Power: 1-500kW	Power: 4-200kW	Power: 500W->	Power: 5kW-1MW
Ceramic wirewound	Steel tube	Wirewound	Steel grid	Steel tube

Danotherm Electric A/S
 Maarkaervej 1-3
 DK-2630 Taastrup
 Denmark
 CVR 1012 6061

www.danotherm.dk
sales@danotherm.dk

DAN EN 16.5042.R4
 7DEC2022